

DIAPHRAGM



907 SERIES

MODELS

907CDC18

907BDC22



FEATURES

- Oil-less operation
- Permanently lubricated bearings
- Field service capability
- Stainless steel valves and aluminum valve plate
- Lightweight die-cast aluminum head and diaphragm hold down plate
- Long-life diaphragm
- Inlet filter
- Balanced for smooth, low vibration operation
- Service Kit SK927

Consult factory for custom applications

Thomas Division is an ISO 9001 registered company

THOMAS
A Gardner Denver Product

USAThomas.com

(800) 799-4568 | 3810 Prospect Ave, Ste. A, Yorba Linda, CA 92886

907 Series Performance Data

MODEL NUMBER		907CDC18		907BDC22	
HEAD CONFIGURATION		Pressure/Vacuum		Vacuum	
STROKE		.180 Inches		.220 Inches	
PRESSURE		Flow @ 12v		Flow @ 12v	
CFM @ PSI	LPM @ bar				
PSI	bar	CFM	LPM	CFM	LPM
0	0	2.05	58.0		
5	.5	1.67	42.5		
10	1.0	1.30	27.3		
15	1.5	.93	18.4		
20	2.0	.72	10.9		
25	3.0	.53			
30	5.0	.35			
35	7.0				
40	10.0				
MAX. CONTINUOUS PRESSURE		30 PSI	2.1 bar		
VACUUM		Flow @ 12 v		Flow @ 12 v	
CFM @ IN. hg	LPM @ mbar (gauge)				
IN. hg	mbar (gauge)	CFM	LPM	CFM	LPM
0	0	2.05	58.0	1.80	60.0
5	-100	1.25	44.6	1.34	43.3
10	-200	.82	33.1	.88	35.6
15	-400	.48	19.7	.56	21.6
20	-600		8.3		10.9
MAX. VACUUM		22.2"hg	-751 mbar	24.8"hg	-841 mbar
MAX. AMBIENT AIR TEMP.		104° F	40°C	104° F	40°C
MIN. AMBIENT START TEMP.		50° F	10°C	50° F	10°C
MAX. RESTART PRESSURE		5 PSI	.3 bar		
MAX. RESTART VACUUM		21.9"hg	-741 mbar	24.1"hg	-817 mbar
MOTOR VOLTAGE/FREQUENCY		12v DC		12v DC	
MOTOR TYPE		Permanent Magnet		Permanent Magnet	
CURRENT AT RATED LOAD (AMPS)		10.8		7.7	
POWER AT RATED LOAD (WATTS)					
STARTING CURRENT (LOCKED ROTOR, AMPS)		40.0		20.0	
MIN. FULL LOAD SPEED (RPM)		2680		2504	
THERMAL PROTECTOR		No		No	
NET WEIGHT		6.5 lbs.	2.9 kg	6.5 lbs.	2.9 kg

The information presented in this material is based on technical data and test results of nominal units. It is believed to be accurate and reliable and is offered as an aid to help in the selection of Thomas products. It is the responsibility of the user to determine the suitability of the product for his intended use and the user assumes all risk and liability whatsoever in connection therewith. Thomas Industries does not warrant, guarantee or assume any obligation or liability in connection with this information.

NOTE: Models pictured are representative of the series and do not represent a specific model number. Consult factory for detailed physical description.

907CDC18

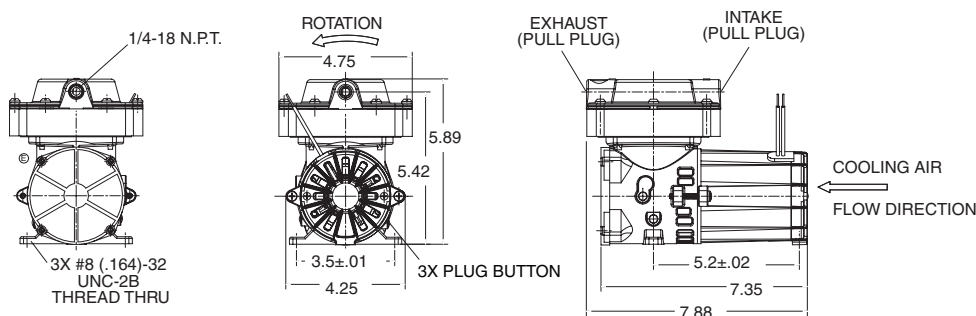

THOMAS
A Gardner Denver Product